

LV equipment LAMP ARMS AND HOLDERS ŻN rod arm holder

P199104

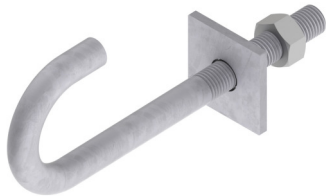

WERSJA MATERIAŁOWA:

hot galvanised steel

OPIS:

The holder is used to mount the lamp arm on ŻN poles.

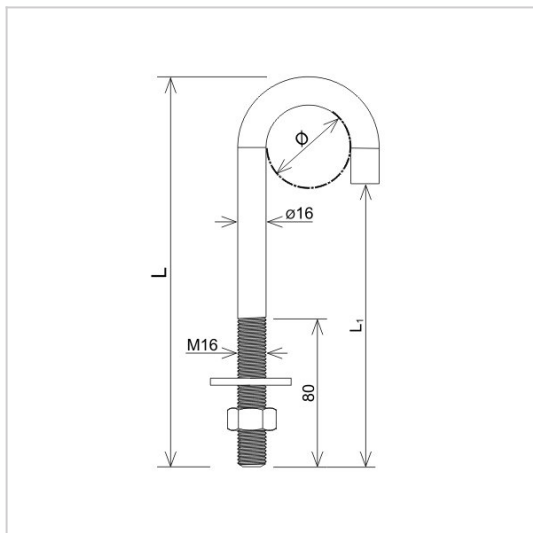

symbol typ	P199104 AN-104D/OG/
L(mm)	220
L1(mm)	160
Ø(mm)	48,3
wersja materiałowa	hot galvanised steel



AN-KOM 2 Sp. z o.o.
Inwałd, ul. ks. Władysława
Bukowińskiego 15
34-120 Andrychów



an-kom.pl
sales@an-kom.pl



tel./fax
+48 605 527 132