

**HOLDERS ROOF TILE universal holder**

**E194716**

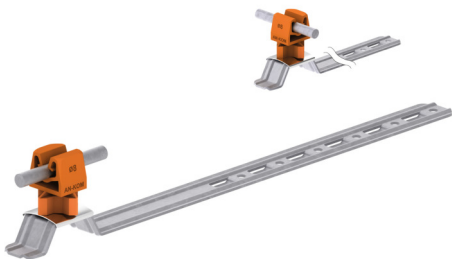

**WERSJA MATERIAŁOWA:**

hot galvanised steel

**OPIS:**

Tile holder - adjustable is used to build air terminals and lightning conductors on the roof across or along the tile. The holder is installed by bending the notch and inserting the holder between the tiles or screwing it to the batten with screws through the mounting holes.

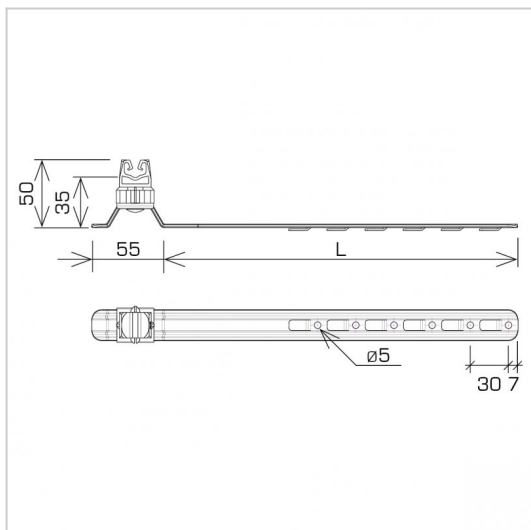

<b>symbol</b> typ	<b>E194716</b> AN-20KPN/OG/-N
<b>pole colour</b>	RAL 8004
<b>L(mm)</b>	420
<b>cablę(mm)</b>	Ø8
<b>wersja materiałowa</b>	hot galvanised steel



AN-KOM 2 Sp. z o.o.  
 Inwałd, ul. ks. Władysława  
 Bukowińskiego 15  
 34-120 Andrychów



an-kom.pl  
 sales@an-kom.pl



tel./fax  
 +48 605 527 132